

AMP CONDENSING BOILERS - SUBMITTAL DATA SHEET

RATINGS AND CAPACITIES

Input - Low Fire	250,000	BTU/HR
Input - High Fire	1,250,000	BTU/HR
Output - High Fire	1,212,500	BTU/HR
Boiler Horsepower	36.2	BHP
Thermal Efficiency	97.0%	
Low Fire Thermal Efficiency	Up to 99%	
Heating Surface	91.6	Sq.Ft.
Water Content	11.0	Gallons
Fuel Natural Gas		
Firing Rate Full Modulation		
Burner Turndown	5:1	
Low NOx Emissions	< 10 ppm	
Inlet Gas Pressure (NG)	4" wc	Min.
	14" wc	Max.
Shipping Weight, Approximate	780	lbs

ASME Section IV (Max 160 PSIG / 210°F)



ETL Certified to UL 795 and CAN 3.1.1



DIMENSIONS / CONNECTIONS

- Height 42-3/4"
- Width 34-1/4"
- Length 45-1/2"
- Supply Connection 3" Grooved
- Return Connection 2-1/2" Grooved
- Vent / Air Intake Connections 8"
- Gas Connection 1" NPT

STANDARD EQUIPMENT

- ASME Stainless Steel Heat Exchanger
- Stainless Steel Pre-Mix Burner
- Variable Speed Combustion Blower
- Concert Boiler Control™ (24v)
- High Limit Temperature Control, Auto Reset
- High Limit Temperature Control, Manual Reset
- Water Flow Switch
- Low Water Cutoff, Manual Reset
- Condensate Trap
- Blocked Condensate Switch
- ASME Pressure Relief Valve
- Pressure / Temperature Gauge
- Supply & Return Temperature Sensors
- Flue Gas Temperature Sensor
- Air Vent Valve
- Modulating Gas Valve
- Direct Spark Ignition and UV Scanner
- High/Low Gas Pressure Switches, Manual Reset
- Combustion Air Switch
- Blocked Vent Switch
- 120/1/60 Line Voltage (< 9 amps)
- 208-240v/1ph/60hz Line Voltage (< 4.5 amps)
- Category IV Individual Venting
- Category II Common Venting with Engineered Vent System
- CPVC, Polypropylene & Stainless Steel Acceptable *Material
- Sealed or Room Combustion Air Intake
- Up to 200 ft equivalent venting / air intake

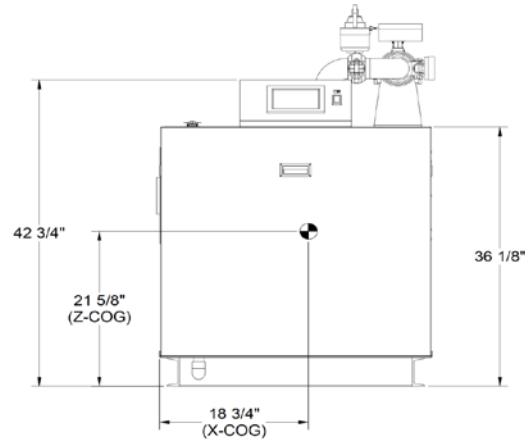

Front View

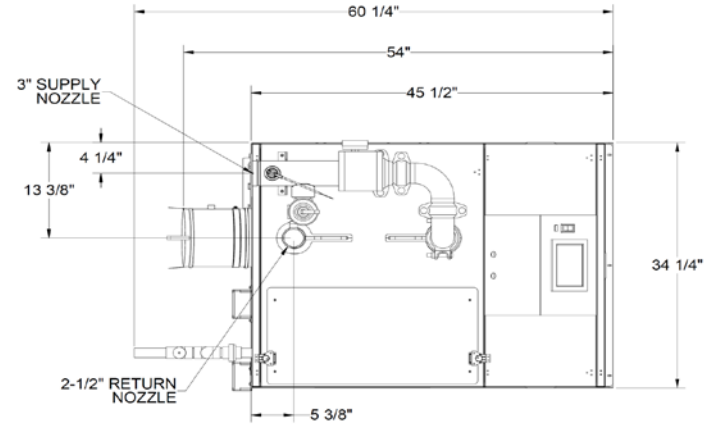

Top View

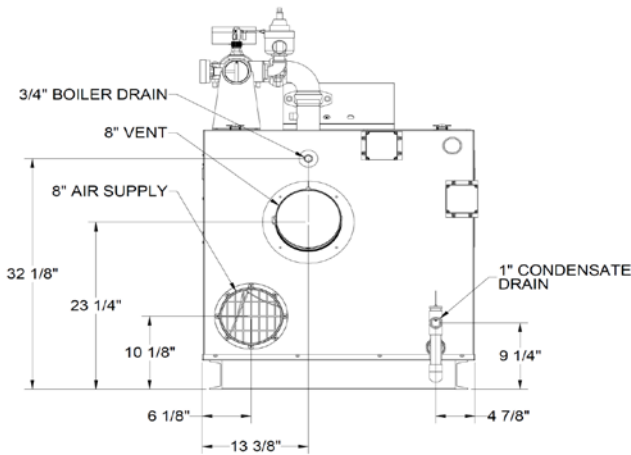

Rear View

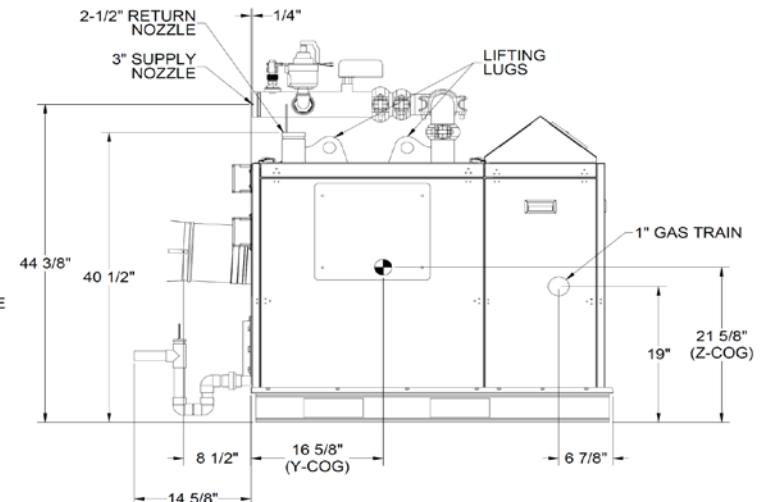

Left Side View

NOTES: 1. Dimensions shown are for reference only

FLOWS AND PRESSURE DROPS

Delta T	Flow (GPM)	Δ P (Ft. Hd)
20°F Δ T	121	16.0
25°F Δ T	97	11.0
30°F Δ T	81	7.2
35°F Δ T	69	6.1
40°F Δ T	61	5.2
45°F Δ T	54	3.8
50°F Δ T	50	3.0
55°F Δ T	44	2.8

* 1. Flue system material shall be capable of continuous operation at 210°F or higher and shall be certified to UL 1738 – venting system for gas-burning appliances cat II, III and IV.

AMP-1250



PROPERTY OF
 PO BOX 3244 | LANCASTER, PA 17601
 INNOVATIVE EQUIPMENT FOR
 HOT WATER SYSTEMS
 WWW.THERMALSOLUTIONS.COM